

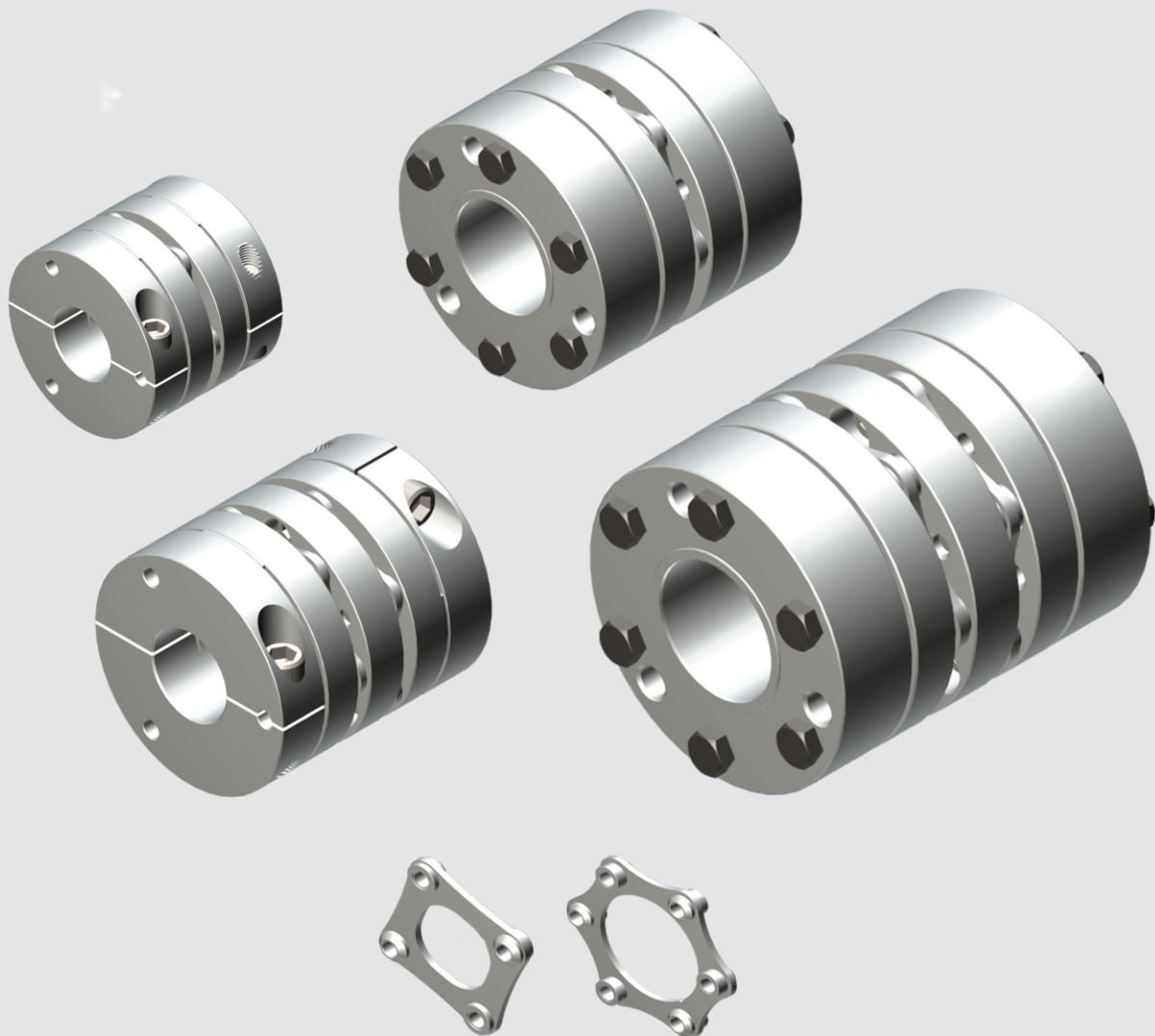

APEX DYNAMICS, INC.

Backlash-Free Servo Coupling

Disc Type



5 Years Warranty !

Coupling - Disc Type

▶ Features:

- ▶ High Precision / Backlash Free
- ▶ High Torque / High Torsional Rigidity
- ▶ High Speed / Low Inertia
- ▶ Permissible Eccentric Angle
- ▶ Shock Absorption for Motor High Gain
- ▶ High Frequency Reciprocating
- ▶ Multiple Choice of Hubs for Input and Output Shaft
- ▶ Easy Axial Installation



Ordering Code - Disc Type

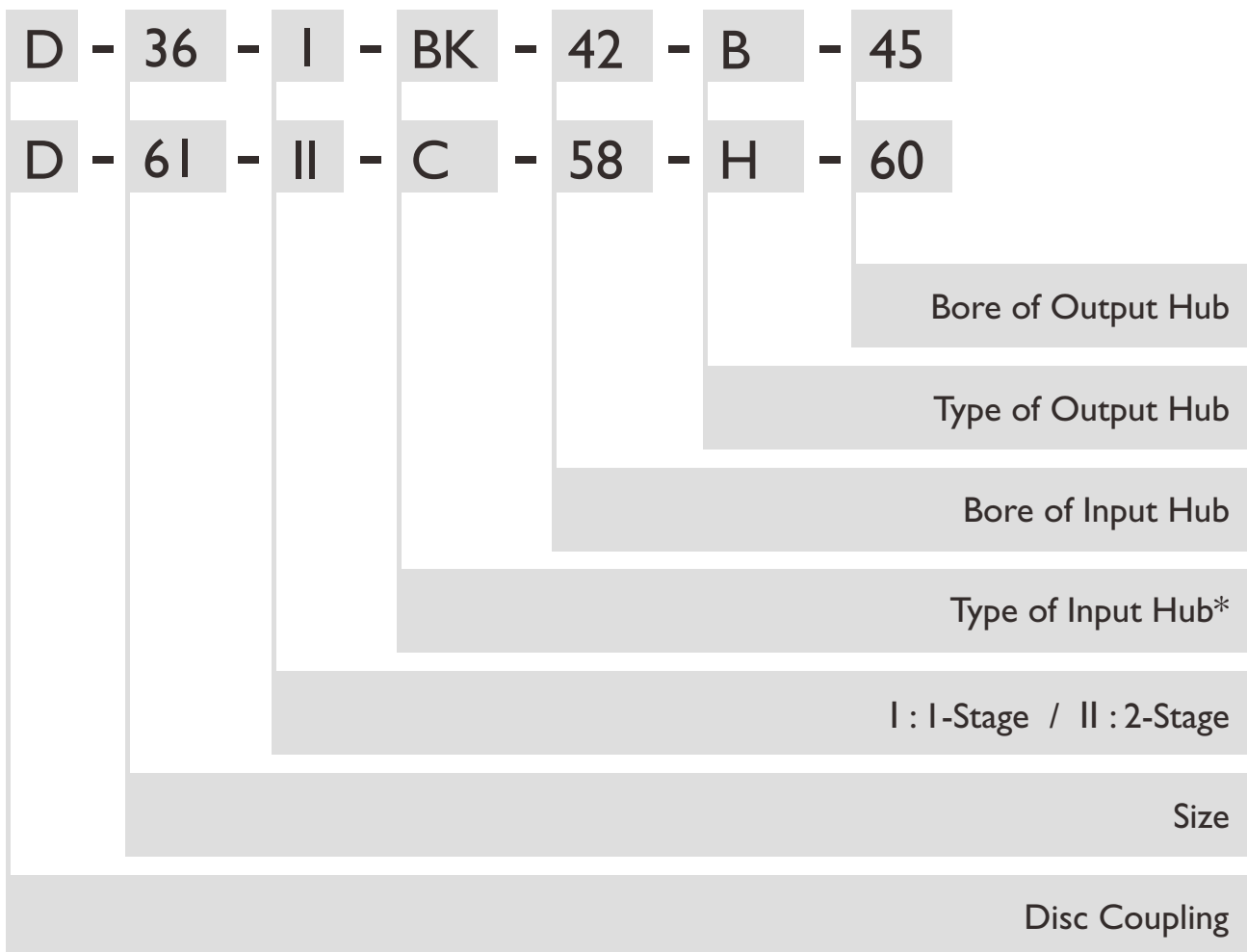

* K for Keyway



©2020 by APEX DYNAMICS, INC.
 APEX DYNAMICS, INC. reserves modification and copyrights of all technical specifications, illustrations and drawings in this catalog in allowance for continuous products development and advancement. For the newest data and information, please visit <http://www.apexdyna.com/>

Type of Hubs

B / BK Type

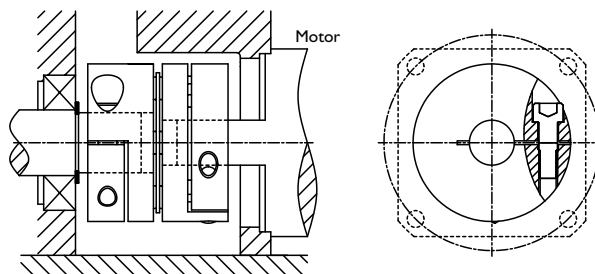
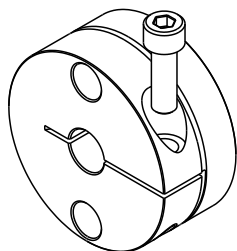

C / CK Type

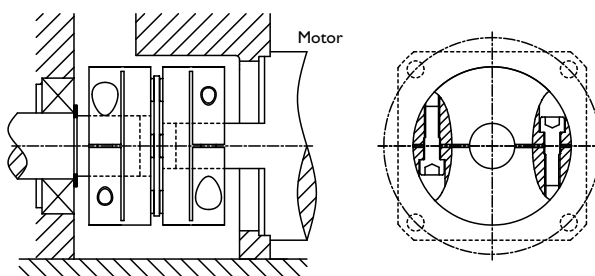
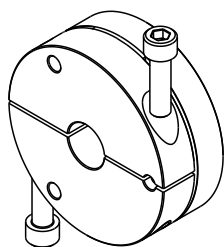

H Type

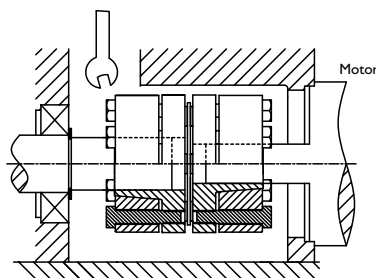
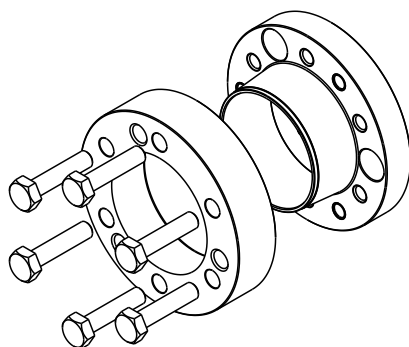

Keyway Dimension

b	Dimension	b	Dimension
2	$6 \leq \text{ØD2} \leq 8$	14	$44 < \text{ØD2} \leq 50$
3	$8 < \text{ØD2} \leq 10$	16	$50 < \text{ØD2} \leq 58$
4	$10 < \text{ØD2} \leq 12$	18	$58 < \text{ØD2} \leq 65$
5	$12 < \text{ØD2} \leq 17$	20	$65 < \text{ØD2} \leq 75$
6	$17 < \text{ØD2} \leq 22$	22	$75 < \text{ØD2} \leq 85$
8	$22 < \text{ØD2} \leq 30$	25	$85 < \text{ØD2} \leq 95$
10	$30 < \text{ØD2} \leq 38$	28	$95 < \text{ØD2} \leq 110$
12	$38 < \text{ØD2} \leq 44$	32	$110 < \text{ØD2} \leq 130$

* Finish bore with keyway which $>\text{Ø}6$, acc. to DIN 6885/1 JS9.

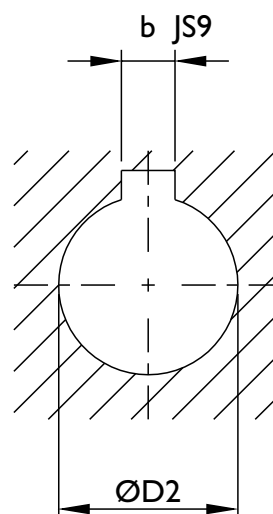

B / BK Type Hub

Type I : 1 Stage

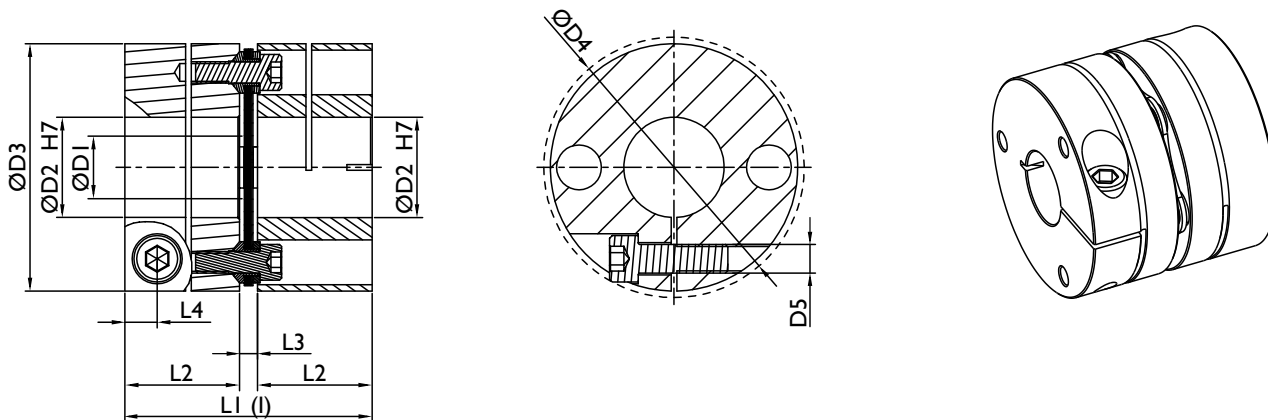

Type II : 2 Stage

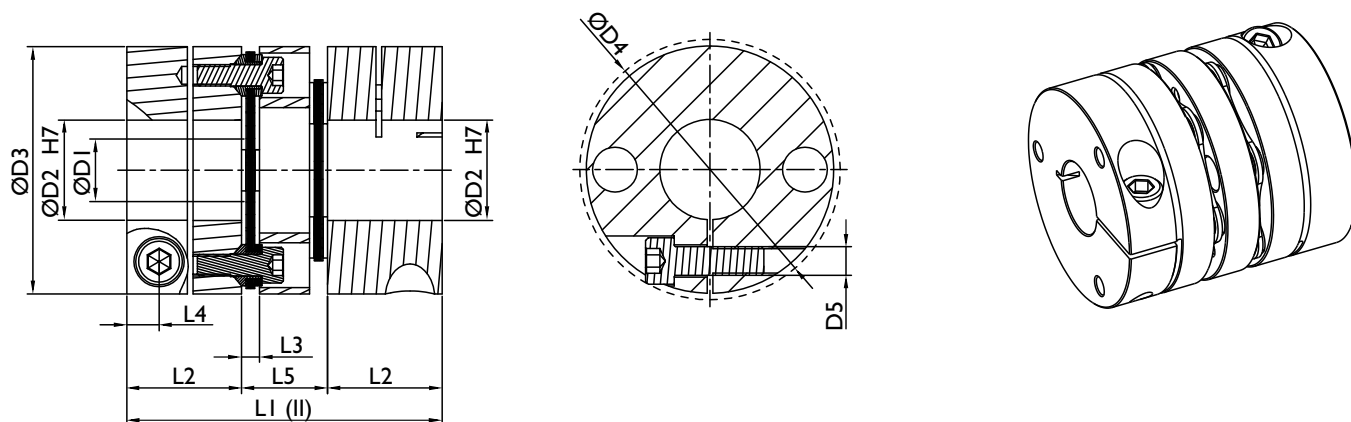

Material:
 Hub: Aluminum.
 Spacer: Aluminum.
 Disc: Stainless Steel.

SIZE	Dimensions [mm]										Clamping Screws ISO 4762		Mass moment of inertia [$\times 10^{-3} \text{ kgm}^2$]	
	D1	D2 max	D3	D4	L1 1-Stg.	L1 2-Stg.	L2	L3	L4	L5	D5	T _A [Nm]	Type I 1-Stg.	Type II 2-Stg.
05	12	12	26	26	26.5	34	12	2.5	3.5	10	M2.5	0.8	0.003	0.004
10	14.5	15	35	35	35	44	16	3	5	12	M4	3	0.013	0.016
16	19.5	20	46	49	47	58	22	3	6.8	14	M6	10	0.052	0.064
21	24	30	58	59	53.5	69	25	3.5	6.8	19	M6	10	0.150	0.191
26	30	38	69	73	69	88	32	5	9	24	M8	25	0.390	0.493
36	48	45	84	87	74.8	93.6	35	4.8	10.5	23.6	M10	49	0.969	1.203

B / BK Type Hub

SIZE	T _{KN} [Nm]	T _{K max} [Nm]	Max Speed [rpm]	Torsional Rigidity [Nm/rad]		Displacements of Type I / 1-Stg.			Displacements of Type II / 2-Stg.		
				1-Stg.	2-Stg.	Radial [mm]	Axial [mm]	Angular [degree]	Radial [mm]	Axial [mm]	Angular [degree]
05	2.5	5	18,300	2,400	1,200	-	±0.2	1	0.13	±0.4	2
10	7.5	15	13,600	5,600	2,800	-	±0.4	1	0.16	±0.8	2
16	35	53	10,500	20,000	10,000	-	±0.5	1	0.19	±1.0	2
21	70	105	8,500	40,000	20,000	-	±0.6	1	0.27	±1.2	2
26	120	180	7,000	84,000	42,000	-	±0.8	1	0.33	±1.6	2
36	340	510	5,700	280,000	140,000	-	±1.0	1	0.32	±2.0	2

Bore and Transmittable Torques TR* [Nm]																						
SIZE	HOLE**	Ø3	Ø5	Ø8	Ø10	Ø12	Ø14	Ø15	Ø16	Ø19	Ø20	Ø22	Ø24	Ø25	Ø28	Ø30	Ø32	Ø35	Ø38	Ø40	Ø42	Ø45
05	2.5	1.2	1.9	2.8	3.5	4.1																
10	4.5		4.9	7.5	9.1	10	12	12.7														
16	5.5				26	30	34	36	38	44	46											
21	7.5					37	40	42	44	50	52	56	60	61	69	71						
26	9.5							80	84	97	100	108	115	119	129	136	142	154	160			
36	11.5									164	171	183	196	201	219	230	241	260	269	274	280	288

* The transmittable torques TR is given based on clamping force, without considering key/keyway.

** The preset pilot bore diameter, in mm based on tolerance standard DIN ISO 2768-1.

*** When the ØD2<6, keyway type is not supported.

C / CK Type Hub

Type I : 1 Stage

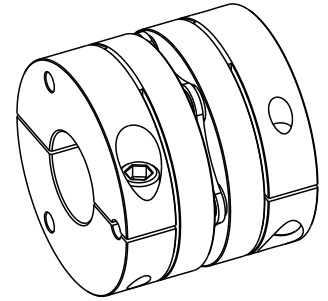
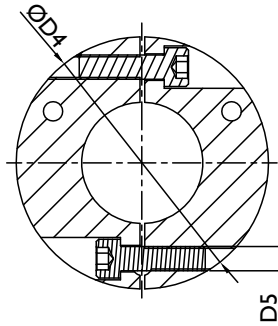
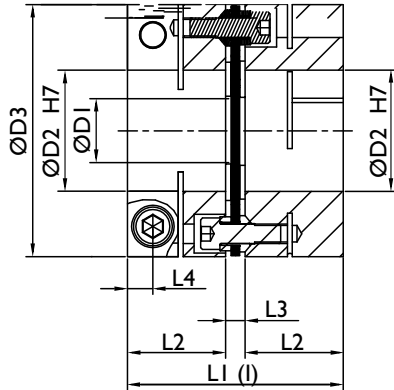

Type II : 2 Stage

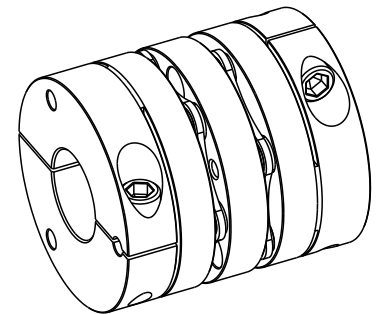
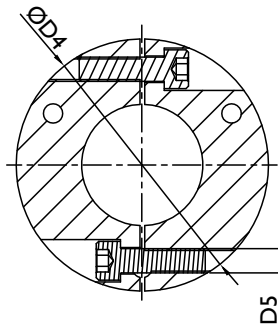
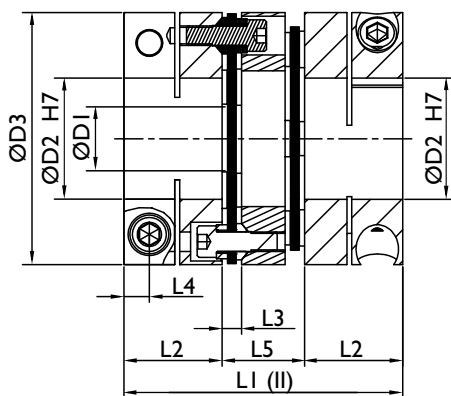

Material:
Hub: Aluminum.
Spacer: Aluminum.
Disc: Stainless Steel.

SIZE	Dimensions [mm]										Clamping Screws ISO 4762		Mass moment of inertia [$\times 10^{-3} \text{ kgm}^2$]	
	D1	D2 max	D3	D4	L1 I-Stg.	L1 2-Stg.	L2	L3	L4	L5	D5	T _A [Nm]	Type I I-Stg.	Type II 2-Stg.
43	61	55	104	104	89	115	40.5	8	10.5	34	M10	49	2.762	3.538
51	73	70	124	130	108	138	50	8	14	38	M14	135	6.973	8.845
61	88	80	144	148.5	118	150	54	10	16	42	M16	210	13.612	17.108

C / CK Type Hub

SIZE	T _{KN} [Nm]	T _{K max} [Nm]	Max Speed [rpm]	Torsional Rigidity [Nm/rad]		Displacements of Type I / 1 Stg.			Displacements of Type II / 2 Stg.		
				1-Stg.	2-Stg.	Radial [mm]	Axial [mm]	Angular [degree]	Radial [mm]	Axial [mm]	Angular [degree]
43	600	900	8,100	510,000	255,000	-	±1.1	1	0.45	±2.2	2
51	1,300	1,950	6,700	920,000	460,000	-	±1.25	1	0.52	±2.5	2
61	2,000	3,000	6,100	1,500,000	750,000	-	±1.3	1	0.62	±2.6	2

Bore and Transmittable Torques TR* [Nm]																				
SIZE	HOLE**	Ø24	Ø25	Ø28	Ø30	Ø32	Ø35	Ø38	Ø40	Ø42	Ø45	Ø48	Ø50	Ø55	Ø58	Ø60	Ø65	Ø70	Ø75	Ø80
43	15	255	264	292	311	329	355	381	398	415	440	465	481	521						
51	28				651	689	746	802	839	875	928	981	1016	1101	1152	1185	1266	1360		
61	30							1096	1147	1198	1271	1346	1394	1512	1583	1630	1743	1856	1964	2073

* The transmittable torques TR is given based on clamping force, without considering key/keyway.

** The preset pilot bore diameter, in mm based on tolerance standard DIN ISO 2768-1.

*** Finished bore diameter >Ø6 keyway, according to DIN 6885/1, dimensional tolerance is JS9, dimensions see Page 4.

H Type Hub

Type I : 1 Stage

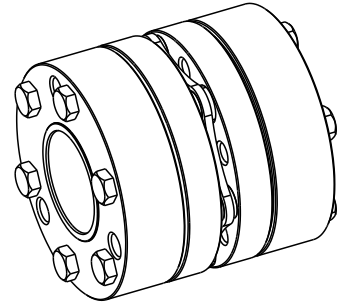
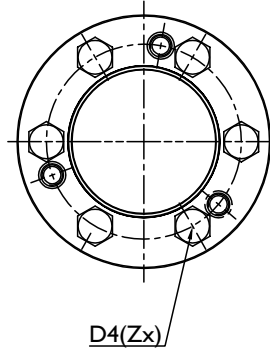
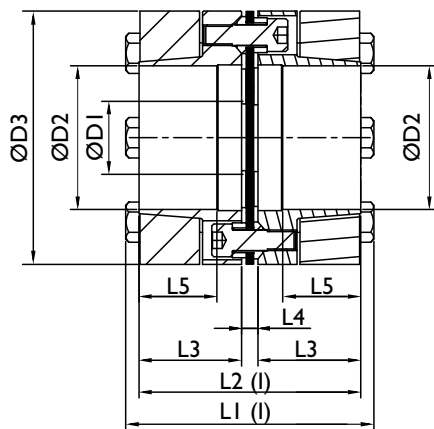

Type II : 2 Stage

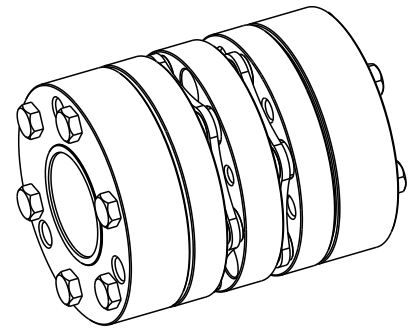
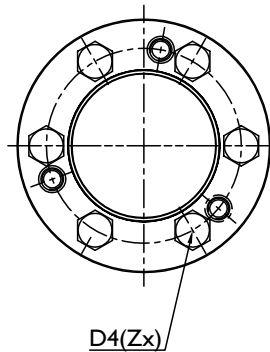
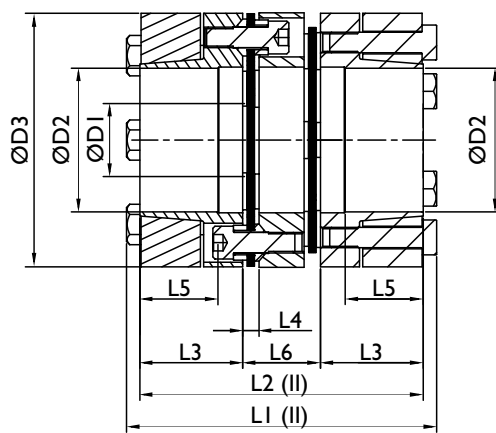

Material:
Hub: Aluminum.
Spacer: Aluminum.
Disc: Stainless Steel.

SIZE	Dimensions [mm]											Clamping Screws ISO 4017			Mass moment of inertia [$\times 10^{-3} \text{ kgm}^2$]	
	D1	D2 max	D3	L1 1-Stg.	L1 2-Stg.	L2 1-Stg.	L2 2-Stg.	L3	L4	L5	L6	D4	z	T _A [Nm]	Type I 1-Stg.	Type II 2-Stg.
16	19.5	20	46	57	68	51	62	24	3	18	14	M5	4	6	0.062	0.074
21	24	28	58	65.7	81.2	59.5	75	28	3.5	22	19	M6	4	10	0.180	0.221
26	30	35	69	81.8	100.8	77	96	36	5	28	24	M5	8	6	0.465	0.568
36	48	42	84	100.8	119.6	90.8	109.6	43	4.8	35	23.6	M8	6	25	1.290	1.523
43	61	60	104	110	136	100	126	46	8	35	34	M8	6	25	3.257	4.056
51	73	70	124	121	151	108	138	50	8	38	38	M10	6	49	7.327	9.205
61	88	80	144	135	167	120	152	55	10	43	42	M12	6	85	14.345	17.785

H Type Hub

SIZE	T _{KN} [Nm]	T _K max [Nm]	Max Speed [rpm]	Torsional Rigidity [Nm/rad]		Displacements of Type I / 1 Stg.			Displacements of Type II / 2 Stg.		
				1-Stg.	2-Stg.	Radial [mm]	Axial [mm]	Angular [degree]	Radial [mm]	Axial [mm]	Angular [degree]
16	35	53	31,150	20,000	10,000	-	±0.5	1	0.19	±1.0	2
21	70	105	24,700	40,000	20,000	-	±0.6	1	0.27	±1.2	2
26	120	180	20,800	84,000	42,000	-	±0.8	1	0.33	±1.6	2
36	340	510	17,100	280,000	140,000	-	±1.0	1	0.32	±2.0	2
43	600	900	13,800	510,000	255,000	-	±1.1	1	0.45	±2.2	2
51	1,300	1,950	11,600	920,000	460,000	-	±1.25	1	0.52	±2.5	2
61	2,000	3,000	10,000	1,500,000	750,000	-	±1.3	1	0.62	±2.6	2

Bore and Transmittable Torques TR [Nm]																											
SIZE	Tolerance	Ø10	Ø12	Ø14	Ø15	Ø16	Ø19	Ø20	Ø24	Ø25	Ø28	Ø30	Ø32	Ø35	Ø38	Ø40	Ø42	Ø45	Ø48	Ø50	Ø55	Ø60	Ø65	Ø70	Ø75	Ø80	
16	H7/h6	29	33	57	70	50	83	97																			
	H7/k6	34	42	64	76	62	96	109																			
21	H7/h6	27	45	75	91	79	125	145	127	144	201																
	H7/k6	36	56	83	99	93	139	157	169	187	245																
26	H7/h6				104	126	194	169	279	311	338	404	273	357													
	H7/k6				124	145	214	200	305	334	382	444	355	441													
36	H7/h6							241	395	438	521	616	523	664	647	741	841										
	H7/k6							284	430	471	558	646	640	779	778	875	974										
43	H7/h6									426	595	705	647	814	946	1073	980	1163	1360	1200	1072	1372					
	H7/k6									517	684	789	784	916	1096	1219	1144	1332	1534	1376	1370	1669					
51	H7/h6											750	818	1020	1085	1228	1166	1377	1605	1450	1607	2283	2255	2704			
	H7/k6											822	927	1117	1254	1392	1348	1568	1803	1652	1960	2387	2447	2842			
61	H7/h6													880	1074	1211	1264	1480	1597	1750	1911	2097	2542	2669	2718	3168	
	H7/k6													951	1131	1258	1333	1534	1668	1810	2032	2239	2635	2785	2855	3252	

* If ØD2 ≥ 55 and the tolerance is G7/h6, G7/m6.

COUPLING SELECTION ACCORDING TO DIN 740 PART II WITH SPECIFIC FACTORS

Glossary

Rated torque of coupling T_{KN}	Nm	Torque to be continuously transmitted over the entire permissible speed range, taking into account the factors.
Friction torque T_R	Nm	The torque transmitted when the shaft is securely connected to the sleeve.
Rated torque of driving side T_{AN}	Nm	Constant driving torque from the motor.
Peak torque of machine T_S	Nm	Peak torque on the coupling.
Peak torque of driving side T_{AS}	Nm	The peak torque generated when the motor starts or stops.
Mass moment inertia of driving side J_A	kgm^2	Total of moments of inertia existing on the driving side referring to the coupling speed
Mass moment inertia of load side J_L	kgm^2	Total of moments of inertia existing on the load side referring to the coupling speed.
Rotational inertia coefficient of driving side M_A		Factor considering the mass distribution with shocks and vibrations generated on the driving or load side.
Temperature factor S_t		Temperature requirements for the couplings.
Operating factor S_B		Factor for different application.
Starting factor S_Z		The number of start-ups per hour.

COUPLING SELECTION ACCORDING TO DIN 740 PART II WITH SPECIFIC FACTORS

Coefficient / Factor

Temperature Factor S_t	
$\leq 120^\circ\text{C}$	1.0
$\leq 200^\circ\text{C}$	1.1

Operating Factor S_B	
Uniform Motion	1.5
Unequal Motion	2.0
Shock Motion	2.5~4.0
For servo motor	1.5~2.0

Starting Factor S_Z	
Starting Frequency / Hour	
< 20	1.0
< 60	1.2
< 120	1.4
< 180	1.6
< 240	1.8
≥ 240	2.0

Calculation

The rated torque T_{KN} of the coupling must be greater than or equal to the rated torque of the equipment T_{AN} , taking into account the temperature coefficient S_t and the operating coefficient S_B .

$$T_{KN} \geq T_{AN} \times S_t \times S_B$$

The rated torque T_{KN} of the coupling must be greater than or equal to the maximum torque T_s applied to the coupling, taking into account the temperature coefficient S_t and the operating coefficient S_B .

$$T_{KN} \geq T_s \times S_t \times S_B$$

Rotational inertia coefficient at the drive side M_A

$$M_A = J_L / (J_A + J_L)$$

Maximum torque at the drive side T_s

$$T_s = T_{AS} \times M_A \times S_Z$$

Under any operation conditions, the friction torque on the coupling bore may not be exceeded.

$$T_R > T_{AS}$$



**APEX TAIWAN NORTH
ANDTEK AUTOMATION CO.,LTD**
TEL +886-02-82262655
13F-5, NO.2, Jian 8th Rd., Jhonghe Dist., New
Taipei City 235, TAIWAN
sales@andtek.com.tw
www.apexdyan.com



**APEX TAIWAN CENTRAL
ANDTEK AUTOMATION CO.,LTD**
TEL +886-04-23594286
9F-6, NO.925, Sec.4, Taiwan Blvd., Xitun Dist.
Taichung City 407, TAIWAN
sales@andtek.com.tw
www.apexdyan.com



**APEX TAIWAN SOUTH
MEN JENN ELECTRIC CO., LTD.**
TEL +886-06-2337332~6
NO.774, Zhonghua Rd., Yongkang Dist., Tainan
City 710, TAIWAN
menjenn@ms24.hinet.net
www.apexdyan.com



APEX TAIWAN INC. SHANGHAI
TEL +86-21-69220577
NO.128 ZHUYING Road QINGPU Industry Area,
Shanghai, CHINA
sales@apexdyna.cn
www.apexdyan.com



APEX DYNAMICS SHENZHEN, LTD.
TEL +86-755-84516325
NO. 1102A of D area, CFG mansion, Bao Yuan
Road, Bao'an District, Shenzhen, CHINA.
sales@szapexdyna.com
www.szapexdyna.com



APEX DYNAMICS BEIJING, LTD.
TEL +86-10-69570691
NO. 1, Yao Ping Road, Song Zhuang Town, Tongzhou
District, Beijing, CHINA.
bjapexdyna@163.com
www.bjapex.cn



CHONGQING APEX DYNAMICS CO., LTD.
TEL +86-23-67686860
406, Building 5, NO. 68, Jinyu Avenue, Beibu New
Area, Chongqing, CHINA
sales@cqapexdyna.com
www.apexdyna.com



APEX (XIAMEN) DYNAMICS TECHNOLOGY CO., LTD.
TEL +65-652-626228
Unit B-3, 1F., NO. 129, Jingquan Road, Jimei District,
Xiamen, Fujian, CHINA
sales@xmmapexdyna.com
www.xmmapexdyna.com



APEX DYNAMICS USA, INC.
TEL +1-631-2449040
885 Marconi Avenue Ronkonkoma, NY 11779
U.S.A.
sales@apexdynamicsusa.com
www.apexdynamicsusa.com



APEX DYNAMICS KOREA INC
TEL +82-31-8179992
7-5, Aenigol-gil, Ilsandong-gu, Goyang-si, Gyeonggi-do,
Republic of Korea 10301
sales@apexdynakorea.co.kr
www.apexdynakorea.co.kr



APEX DYNAMICS JAPAN
TEL +88-092-4511202
1-3-46, Hannichibasi, Hakata-ku, Fukuoka,
812-0897, JAPAN
sales@apexdyna.jp
www.apexdyna.jp



APEX DYNAMICS SINGAPORE PTE LTD
TEL +34-93-6562990
3 South Buona Vista Road, #05-15 & #06-15.
SINGAPORE 118136
sales@apexdyna.com.sg
www.apexdyna.com.sg



APEX DYNAMICS (THAILAND) CO., LTD.
TEL +66-2-326623
87 Soi Ladkrabang 30, Ladkrabang, Ladkrabang,
Bangkok 10520, Thailand
Apexthai2010@gmail.com
www.apexdyna.co.th



APEX DYNAMICS BV
TEL +31-492-509995
Churchillaan 101 5705 BK Helmond, NETHERLANDS
sales@apexdyna.nl
www.apexdyna.nl



**APEX DYNAMICS
POLSKA SP. Z O.O.**
TEL +48-12-6304728
Ul. Krakowska 50, 32-083 Balice, Poland
sales@apexdyna.pl
www.apexdyna.pl



APEX DYNAMICS SPAIN, S.L.
TEL +34-93-6562990
Carretera Laureà Miró, 407
08980 - Sant Feliu de Llobregat (Barcelona)
apexdyna@apexdyna.es
www.apexdyna.es



Big Diamond Trading Company LLC
TEL +968-94268885
2nd floor, Regus, Tamimah building, Al
Wattayah, Muscat, Oman
ar.gorji@diamondtradings.com



APEKS DINAMIK REDUKTOR DISLI SAN TIC AS
TEL +90-232-4589960
10053 SOKAK NO: 9 A.O.S.B. CIGLI-IZMIR -TURKEY
sales@apexdyna.com.tr
www.apexdyna.com.tr



APEX DYNAMICS AUSTRALIA PTY LTD.
TEL +613-95-852739
36 Taunton Drive, Cheltenham, Victoria 3192
AUSTRALIA.
sales@apexdyna.com.au
www.apexdyna.com.au



APEX DYNAMICS (I) JV
TEL +91-9607927142
Shop No. 02, S. No. 100/5, Pune-Satara Highway,
Ambegaon Khurd, Pune-411046 Maharashtra, India
sales@apexdyna.co.in
www.apexdyna.co.in



APEX DYNAMICS FRANCE SAS
TEL +33-160-135097
11 - Burospace - 91570 - Bièvres, France
info@apexdyna.fr
www.apexdyna.fr



APEX DYNAMICS SWEDEN AB
TEL +46-75-2424444
Fredrikbergsgatan 2 SE-573 92 Tranås, SWEDEN
sales@apexdyna.se
www.apexdyna.se



PT.APEX DYNAMICS INDONESIA
TEL +62 21 2928 3681
Rukan Aralia Blok HY43 no.11, Harapan Indah II,
Bekasi - Jawa Barat, INDONESIA 17214
sales@apexdyna.co.id
www.apexdyna.co.id



APEX DYNAMICS GERMANY GMBH
TEL +49-7171 798069-0
Marie-Curie-Straße 25 D-73529 Schwäbisch Gmünd
werner.langer@apexdynamics.de
www.apexdynamics.de



APEX DYNAMICS CZECH S.R.O.
TEL +420-577-663877
tř. Tomáše Bati 1851 765 02 Otrokovice Česká
REPUBLIKA
info@apexdynaczech.cz
www.apexdynaczech.cz



APEX DYNAMICS РОССИЯ
TEL +7-495-2255452
TEL +7-495-6462422
г.Москва, ул. Южнопортовая, дом 7, строение
"С", 3-й этаж
info@apexdynarussia.ru
www.apexdynarussia.ru



APEX DYNAMICS MIDLANDS LTD
TEL +44-0121-737-1170
Heath House, Cheadle Rd, Uttoxeter,
ST14 7BY, UK
mikeg@apexdynauk.com
www.apexdynauk.com



APEX DYNAMICS SWITZERLAND AG
TEL +41-55-4517020
Obergasse 40, CH-8854 Galgenen, Switzerland
info@apexdyna.ch
www.apexdyna.ch



APEX DYNAMICS MOTION (M) SDN BHDTEL
TEL +60 7237 1055
Block A1-2, #35-03, Mercu 1 Jalan Tanjung Puteri 1,
R & F Tanjung Puteri, Johor Bahru 80300, Johor.
sales@apexdyna.com.sg
www.apexdyna.com.sg



APEX DYNAMICS BRAZIL
TEL +55-47-30298700
Rua Senador Petrônio Portela, 47-Bloco 5, Zona
Industrial Norte-CEP 89218-575-Joinville (SC)
luca@neoyama.com.br
adriano.duarte@neoyama.com.br
www.neoyama.com.br



APEX DYNAMICS ITALY SRL
TEL +39 02 36634521
VIA E. DE AMICIS, 2-20091 BRESSO (MI)
info@apexdynamics.it
www.apexdynamics.it



APEX DYNAMICS AUSTRIA GmbH
TEL +43 720788416
Dr. Hans-Lechner-Strasse 6,
5071 Wals-Siezenheim
info@apexdynamics.at
www.apexdynamics.at



UAB "APEKSO DINAMIKA"
TEL +370 52078165
Medaus g. 28A,
Medininku k., Vilniaus r. Sav.
LT-13192
info@apexdyna.lt



APEX DYNAMICS DENMARK
TEL +45 73121260
Grundtvigs Allé 165, 6400
Sønderborg, Denmark
sales@apexdyna.dk
www.apexdyna.dk



APEX DYNAMICS ISRAEL
TEL +972-3-6470471
17 Hamefalsim St., Kiryat Arye,
Petach-Tikva 4951447
Sales@apexdynamics.co.il
www.apexdynamics.co.il



APEX DYNAMICS SLOVAKIA S.R.O.
TEL +421919400476
Trenčianska cesta 887/52, 957 01
Bánovce nad Bebravou, Slovak republic
office@apexdyna.sk
www.apexdyna.sk



APEX DYNAMICS, INC.

No. 10, Keyuan 3rd Rd., Situn District, Taichung City 40763, Taiwan (R.O.C.)
Tel:886-4-24650219 | Fax:886-4-24650118
sales@apexdyna.com | <http://www.apexdyna.com>

APEX-2024-01-Disc Coupling

Printed in Taiwan

